

MOKA TABLE

Assembly guide

recommandations / recommendations

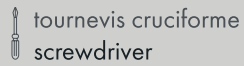
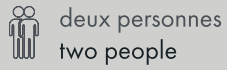

contenu du pack / pack content

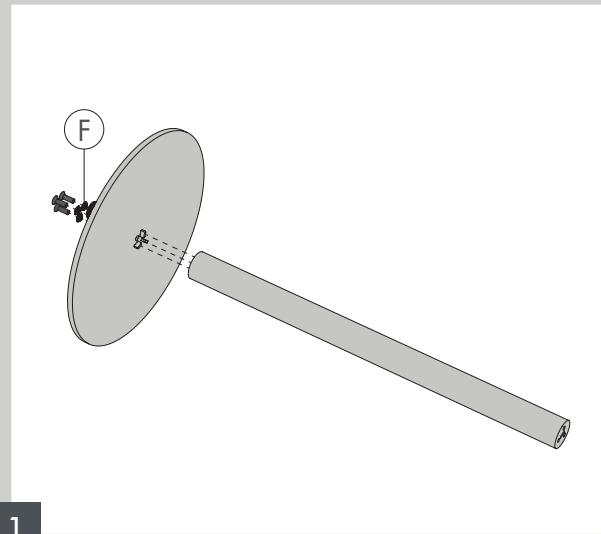
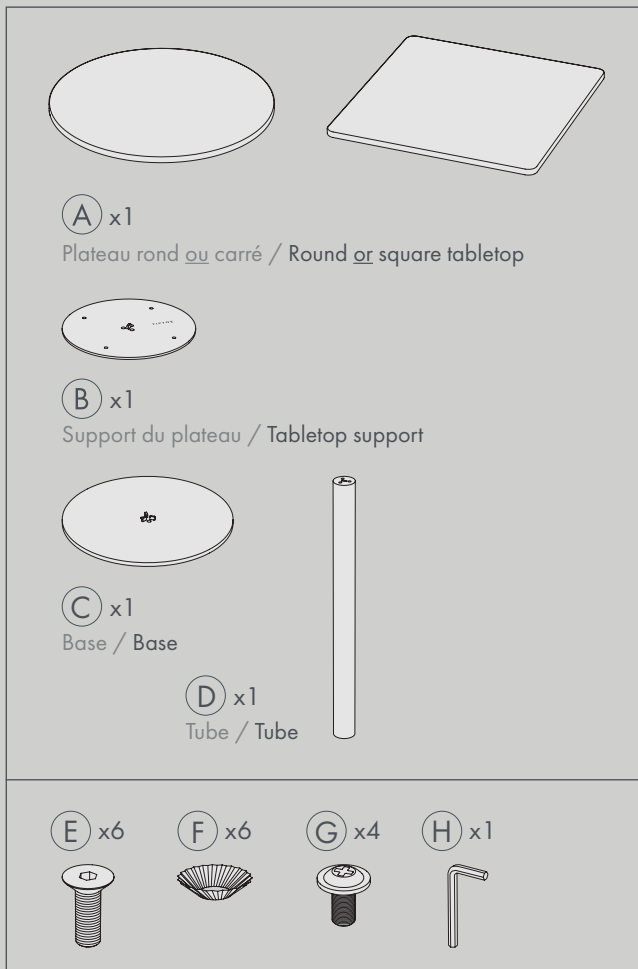

1

Positionnez le tube (D) avec la base (C) en alignant les encoches. Puis, insérez les 3 rondelles (F) et les 3 vis (E)

Position the tube (D) with the base (C), aligning the notches. Then insert the 3 washers (F) and the 3 screws (E)

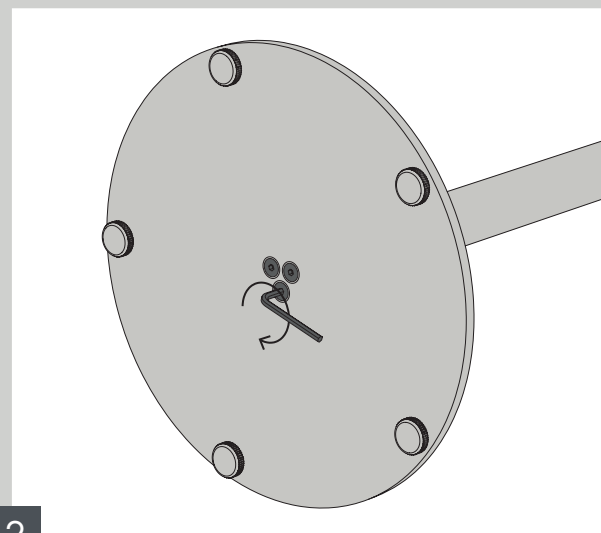

2

À l'aide de la clé Allen (H), serrez les 3 vis (E).
Using the Allen key (H), tighten the 3 screws (E).

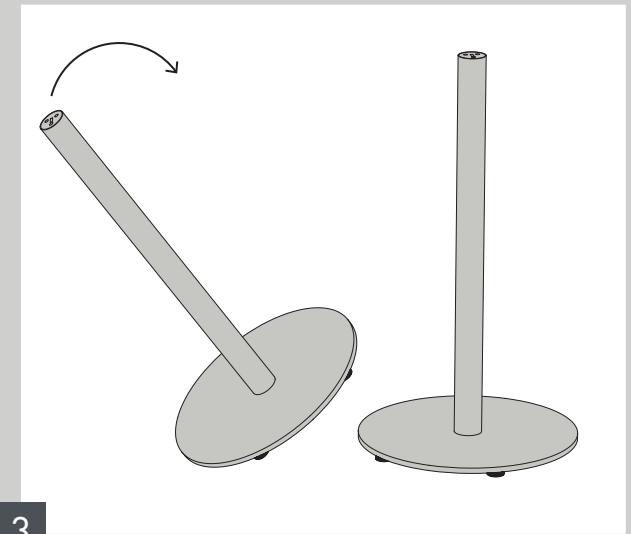

3

Pivotez l'ensemble afin que la base (C) repose au sol.
Swivel the assembly so that the base (C) rests on the floor.

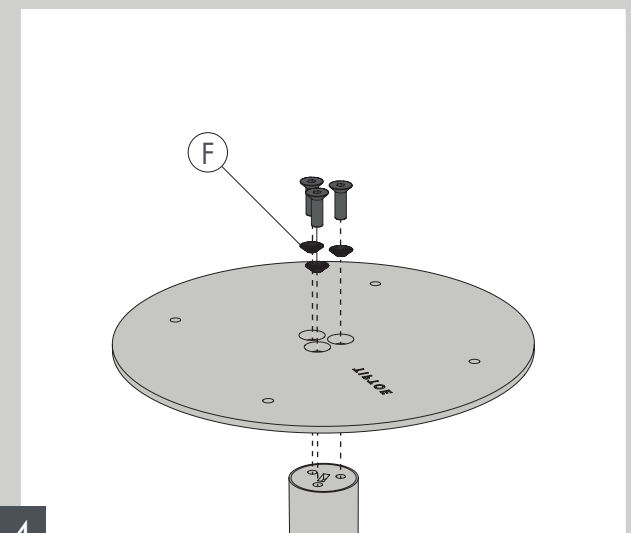

4

Positionnez le support de plateau (B) sur le tube (D) en alignant les encoches. Puis, insérez les 3 rondelles (F) et les 3 vis (E).
Position the tabletop support (B) on the tube (D), aligning the notches. Then insert the 3 washers (F) and the 3 screws (E).

MOKA TABLE

Assembly guide

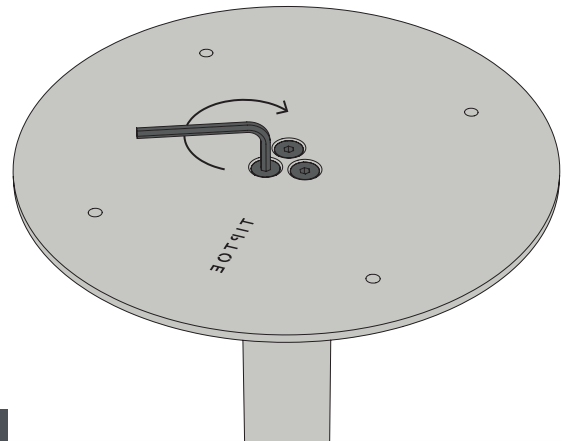

5

À l'aide de la clé Allen (H), serrez les 3 vis (E).
Using the Allen key (H), tighten the 3 screws (E).

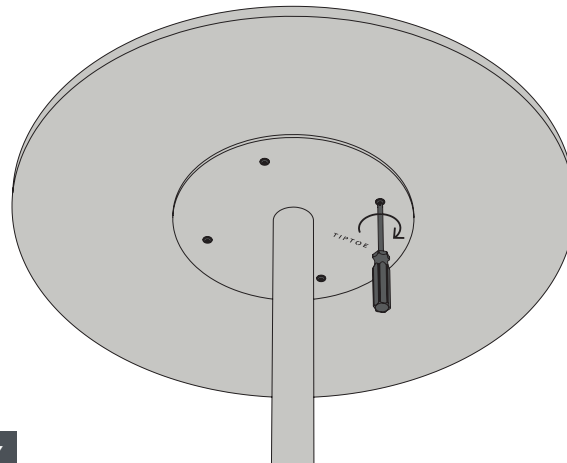

7

Vissez les 4 vis (G) dans le plateau (A) à l'aide d'un tournevis.
Screw the 4 screws (G) into the tabletop (A) with a screwdriver.

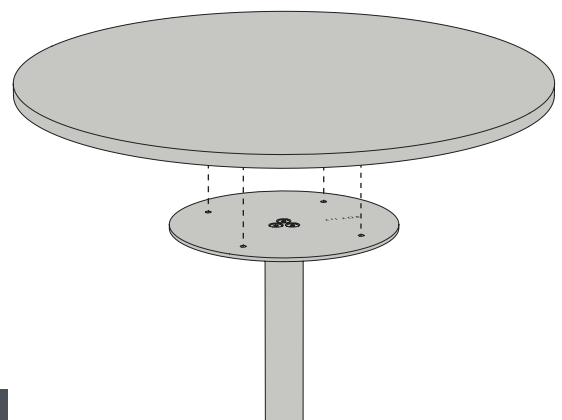

6

Placez le plateau (A) en faisant correspondre les inserts avec les trous du support de plateau (B).
Place the tabletop (A) by matching the inserts with the holes in the tabletop support (B).

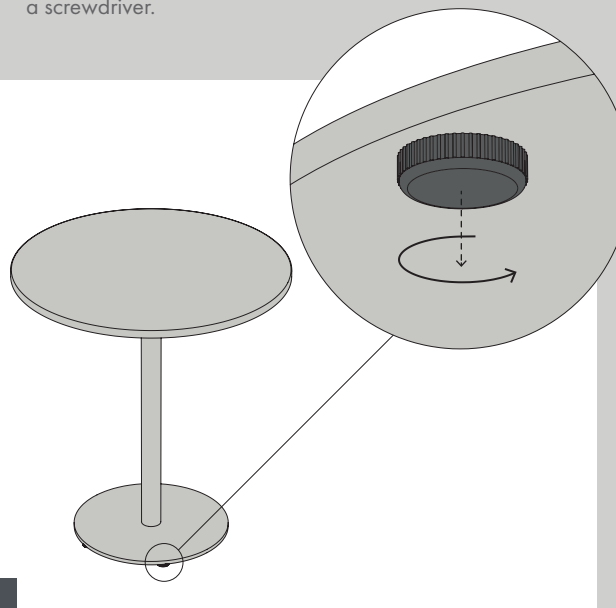

8

Si vous souhaitez ajuster la table, vissez ou dévissez les vérins présents sous la base (C).
If you wish to adjust the table, screw or unscrew the pads present under the base (C).

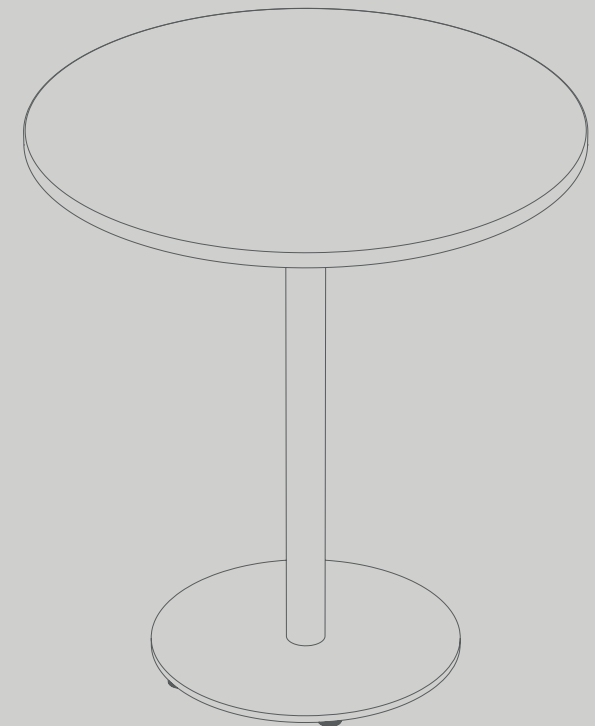

TIPTOE

tiptoe.fr | @tiptoe design